

M22A

2-way bi-amplified active stage monitor

Montarbo
Made in Italy



Optimum performance requires first and foremost excellent monitoring. Accurate voice reproduction and maximum coherence of the acoustic image are indispensable to give one's best.

Designed to meet the most demanding requirements in professional applications, model M22A high-performance self-powered, bi-amplified stage monitor provides high sound pressure level with maximum definition and absolutely flat frequency and phase response.

SYSTEM'S ARCHITECTURE

The combination of a 10" neodymium magnet woofer and a 1" compression driver (polyimide diaphragm) coupled to a Montarbo designed constant directivity horn (90°H x 70°V) can generate an incredible high SPL.

The horn may be rotated 90° to reduce the horizontal dispersion and limit feedback into nearby microphones.

- The built-in electronics includes:
 - 2, **class AB, Mosfet amplifiers**, each one fitted with our exclusive loudspeaker protections and a soft-start circuit to reduce the peak current drain at switch-on. The two on-board power amplifiers deliver a total output power of 300 W divided into 200 W for the bass section and 100 W for the mid/high section.
 - 2 **active dynamic processors**, optimize the specific features of each component and provide direct control of the operation of the systems, ensuring a constantly flat frequency response. They feature independent time constants (and operating thresholds that are sensitive to line voltage) and limit any excessive voice coil movement under the most demanding operating conditions.
 - a **high slope active electronic crossover** (24dB/oct. Linkwitz-Riley) guaranteeing phase coherency and perfect overlapping of acoustic emissions for the transducers in the crossover region.



FEATURES

- High sound pressure level with maximum definition, absolutely flat frequency and phase responses.
- Low susceptibility to feedback. Excellent intelligibility, no distortion or coloration.
- The sound pressure that a M22A is able to generate, as well as its sonic accuracy, are absolutely unusual in conventional stage monitors of this size.
- The dual angle cabinet's profile of M22A allows for maximum setup flexibility and helps in optimizing listening, from short or long distances.
- 2 class AB Mosfet amplifiers eliver a total output power of 300 Watts (LF 200 W, HF 100 W).
- 127 dB max SPL.
- 10" neodymium magnet high-efficiency woofer with 2.5" voice coil.
- 1" compression driver with 2" voice coil.
- 90° x 70° constant directivity horn (Montarbo design).
- The horn may be rotated 90° for reducing the horizontal coverage and limiting feedback into nearby microphones.
- Design and construction conform to the highest professional standards for maximum reliability and durability: strong and sturdy cabinet with highly resistant polyurethane paint finish and steel protection grid; low turbulence tuning ports; all controls and connections are conveniently placed on one side of the cabinet for increased ease of use; an ergonomically designed handle, balanced to the box's centre of gravity, make transport easier.

APPLICATIONS

- Suitable whenever an high level stage monitoring is required.

M22A

2-way bi-amplified active stage monitor

Montarbo
Made in Italy



TECHNICAL SPECIFICATIONS

Enclosure	2-way; vented
Frequency response	45 Hz ÷ 20 kHz ±3dB
Sensitivity	100,5 dB SPL @ 1W/1m (on axis)
Max. SPL	127 dB
Max output power	300 W (LF 200 + HF 100)

- Components
 - bass frequencies 10" neodymium magnet high efficiency woofer (2.5" voice coil)
 - mid/high frequencies 1" compression driver (2" voice coil) constant directivity horn (90°H x 70°V)

Impedance	4 ohms (bass) / 8 ohms (mid/high)
Frequency response	45 Hz ÷ 20 kHz

- Active electronic crossover
 - 24 dB/oct (Linkwitz-Riley)
 - Crossover frequency 1500 Hz

- Built-in power amplifier
 - 2 MosFet, class AB, dedicated power units with 2 independent dynamic processors; 'soft start' circuit

Max output power	300 W
- bass	200 W (4 ohms / 0,1% THD)
- mid/high	100 W (8 ohms / 0,1% THD)
Frequency response	10 Hz ÷ 40 kHz +0/-1dB
Input impedance	10 kOhms (balanced)
Input sensitivity	0 dBu (775mV)
Noise referred to input	- 110 dB (A weighted)

- Connectors
 - balanced Neutrik Combo® input
 - balanced XLR output (link)

- Controls
 - master level
 - independent HF level

PHYSICAL SPECIFICATIONS

- Construction
 - birch multiply cabinet;
 - anti-scratch polyurethane paint;
 - powder coated steel protection grille

- Fittings
 - carrying handle

- Dimensions / Weight
 - W 49.4 x H 27 x D 42.9 cm / 17 kg

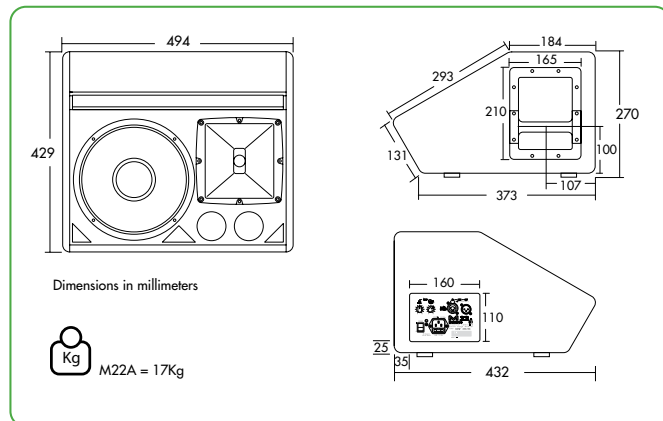

MUSIC - DATA SHEET