



# 115FM

FLOOR  
MONITOR

## APPLICATIONS

Precise and powerful, the L-ACOUSTICS® 115FM floor monitor is the ideal tool for the monitor engineer - especially for high SPL applications. The 115FM is the first floor monitor to combine the advantages of coaxial technology with the pattern control of conical waveguide loading.

The coaxial approach to floor monitor design was pioneered by L-ACOUSTICS with the MTD line and provides unsurpassed coherence in the near field. Advantages of coaxial technology include: single point source radiation and excellent phase response, total wavefront coherency at all frequencies and axi-symmetrical directivity that produces identical horizontal and vertical coverage. Coaxial design also provides LF/HF superimposed dispersion characteristics that are free of polar lobing effects typical of traditional horn and woofer combinations. The end result is natural, studio monitor level sound quality that is ideal for proximity use in floor monitoring applications.

The 115FM combines extremely high sound pressure level capability with exceptional clarity, fidelity and pattern control. The optimum combination of the 15" loudspeaker and the 1.4" neodymium compression driver in a coaxial assembly results in exceptional power response stability with high immunity to feedback. Conical waveguide loading focuses mid/high frequency energy over a 45-degree axi-symmetrical pattern while at the same time loading the 15" loudspeaker for improved upper mid bass efficiency.

The ultra-compact format and low profile of the 115FM allows for optimum sightlines even in the most confined locations. With the flexibility of dual angle configurations, the 115FM can be used for either short- or long-throw monitoring.

The L-ACOUSTICS LLC115FM analog controller provides optimum crossover filtering plus equalization and guarantees safe operation through the use of active sense return monitoring. A subwoofer feed is also available for when the 115FM is used in conjunction with SBI15, SBI18 or SB218 subwoofers for drum fill applications. Front panel design of the LLC115FM allows the unit to function as a patch panel, providing an ergonomic, cost-effective solution for amplifier rack packaging. Alternatively, processing for the 115FM can be provided by an approved digital crossover programmed with OEM factory presets.

## L-ACOUSTICS PROFESSIONAL SOUND SYSTEM



- ▶ **Active two-way enclosure (15" LF, 1.4" HF)**
- ▶ **High Q coaxial driver assembly**
- ▶ **Point source radiation (45° conical directivity)**
- ▶ **Compact, versatile format for short- or long-throw floor monitoring**
- ▶ **Designed for high performance touring**
- ▶ **Compact, rugged construction**
- ▶ **Analog processor control with sense return protection**
- ▶ **OEM factory presets for approved digital processors**

## SPECIFICATIONS

L-ACOUSTICS specifications are based on measurement procedures which produce unbiased results and allow for realistic performance prediction and simulation. Some of these specifications will appear very conservative when compared with other manufacturer's specifications. All measurements are conducted under free field conditions and scaled to a 1 m reference distance unless otherwise indicated.

### Frequency Response

Frequency response	80 - 18k Hz (± 3 dB)	(LLC SINGLE position)
Usable bandwidth	60 - 20k Hz (-10 dB)	

### Sensitivity<sup>1</sup>

LF (2.83 Vrms @ 1m)	99.6 dB SPL	80 - 1k Hz
HF (2.83 Vrms @ 1m)	109.3 dB SPL	1 - 18 kHz

### Power Rating<sup>2</sup>

LF	55 Vrms	375 Wrms	1500 Wpeak
HF	25 Vrms	75 Wrms	300 Wpeak

### Amplification\* (Recommended)

750 W
300 W

### Impedance (Nominal)

8 ohms
8 ohms

\*Amplifiers must have 32 dB gain in order for LLC115FM sense return protection to function properly

### Nominal Directivity (-6dB)<sup>3</sup>

Axi-symmetrical	45° (± 10°)
-----------------	-------------

### System Output<sup>4</sup>

	SPL			
One enclosure	129.0 dB (cont)	135.0 dB (peak)	SINGLE	mode
	130.0 dB (cont)	136.0 dB (peak)	COUPLED	mode
	130.5 dB (cont)	136.5 dB (peak)	X-OVER	mode

### Components

LF	1 x 15" weatherproof loudspeaker (bass reflex-loaded, 3" voice coil)
HF	1 x 1.4" neodymium compression driver mounted on conical waveguide

<sup>1</sup> Sensitivity is the average SPL measured over the component's rated bandwidth

<sup>2</sup> Power rating displays the long term RMS power handling capacity using pink noise with a 6 dB crest factor over the component's rated bandwidth

<sup>3</sup> Directivity is averaged over the 1-10 kHz range

<sup>4</sup> System Output gives the unweighted SPL output of the system referenced to 1 m, including preset equalization and band leveling adjustment

### Enclosure

- Height 370 mm 14.6 in
- Width 580 mm 22.8 in
- Depth 410 mm 16.1 in
- Projection angles : 35° or 55° with respect to vertical axis
- Weight (net) 29.5 kg 65.0 lbs
- Shipping weight 32.5 kg 71.6 lbs
- Shipping dims 615 x 470 x 465 mm 24.2 x 18.5 x 18.3 in
- Connectors : 2x 4-pin Neutrik speakon
- Material : Baltic Birch plywood
- Finish : Maroon-gray™
- Grill : Black epoxy perforated steel with acoustically transparent foam
- Handles : 2 integrated handles on both sides of the enclosure

### Additional Equipment

- L-ACOUSTICS LLC115FM analog controller
- L-ACOUSTICS LA 24a power amplifier
- OEM factory presets available for approved digital processors

## ARCHITECT SPECIFICATIONS

The enclosure shall be an active, two-way, coaxial full range loudspeaker containing one direct radiating, bass reflex-loaded, 15 inch low frequency transducer and one 1.4 inch exit, titanium alloy diaphragm, neodymium compression driver. As a full range system, the frequency response shall be 80 Hz to 18 kHz with less than  $\pm 3$  dB variation and the usable bandwidth shall be 60 Hz to 20 kHz (-10 dB).

Pattern control loading for the compression driver shall be provided by a concentrically-mounted conical waveguide that yields a 45-degree conical dispersion pattern that is axi-symmetrical. The crossover point between low and high frequency components shall be 1 kHz with 24 dB per octave Linkwitz-Riley characteristics. Long term power handling shall be 375 Wrms for the low section and 75 Wrms for the high section at a nominal 8-ohm impedance. Connection to the loudspeaker shall be made via two parallel 4-pin Neutrik Speakon connectors.

The enclosure shall have a profile that is suitable for stage monitoring applications, offering two listening angles of 35- or 55-degrees with respect to a vertical axis perpendicular to the floor. Dimensions shall be 58 cm (22.8 in) wide, 37 cm (14.6 in) high, 41 cm (16.1 in) deep. Net enclosure weight shall be 29.5 kg (65 lbs). Cabinet construction shall consist of 18 mm (0.70 in) Baltic birch plywood with joints that are sealed, screwed and rabbeted. The finish shall be maroon-gray high resilient paint. The front of the enclosure shall be protected by 1.5 mm (0.06 in) thick black epoxy-coated steel grill, that is covered with 10 mm (0.39 in) thick acoustically transparent open cell foam.

The enclosure shall be used with a mono analog controller that monitors power amplifier outputs and employs sense return processing to provide thermal protection and cone excursion limiting for the loudspeaker components. The analog controller shall provide band limiting and corrective component equalization with three settings that are designed for single, coupled or three-way operation with subwoofers. The analog controller shall provide a line level output signal with selectable band limiting and equalization for use of the enclosure in conjunction with three different subwoofer types.

Alternatively, the enclosure shall be used with an approved digital processor with OEM factory presets for active 2-way or 3-way operation in conjunction with additional subwoofer enclosures.

The loudspeaker system shall be the L-ACOUSTICS I15FM.

The analog loudspeaker controller shall be the L-ACOUSTICS LLC I15FM.

The subwoofer system shall be the L-ACOUSTICS SB115, SB118, SB218 or dV-SUB.

## ACCESSORIES

No dedicated accessories have been specifically designed for the I15FM.

**Loudspeaker Cable:** Loudspeaker connection shall be made via 4-conductor cable using standard Neutrik Speakon wiring: 1+ = low positive, 1- = low negative, 2+ = high positive, 2- = high negative.

**Flight Case:** Two I15FM speakers can be transported in one flight case. The minimum space required is achieved when the bottom panels of the two enclosures are facing each other while each I15FM is laying on its side. The internal dimensions of the case are then: 58 cm (22.8 in) high x 74 cm (29.2 in) wide x 41 cm (16.1 in) deep.

**Configuration:** The I15FM is designed for multiple source floor monitoring applications. Coupling enclosures side-by-side will produce interference in the mid-high frequencies while increasing the low frequency response. The best results are obtained when the enclosures are separated by at least 0.5 m (short throw mode) or 1 m (long throw mode). The correct projection angle, either 35° or 55° from the vertical axis, depends on the listening area to be covered (short throw or long throw mode, respectively).

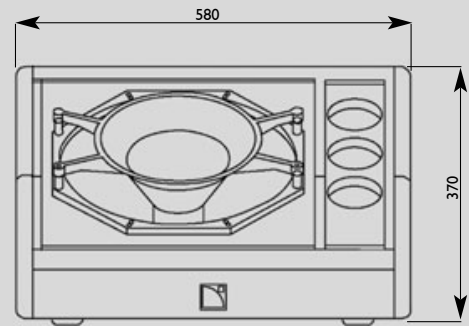

FRONT

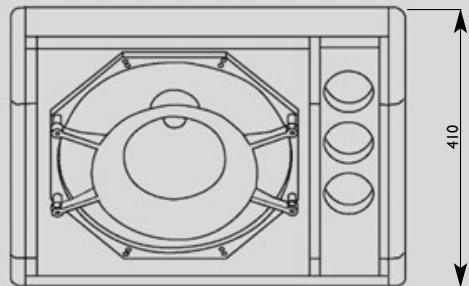

TOP



REAR

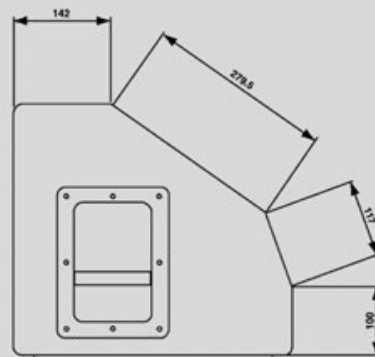

SIDE

SCALE 1:10



# 115FM

PERFORMANCE  
DATA

## FREQUENCY RESPONSE

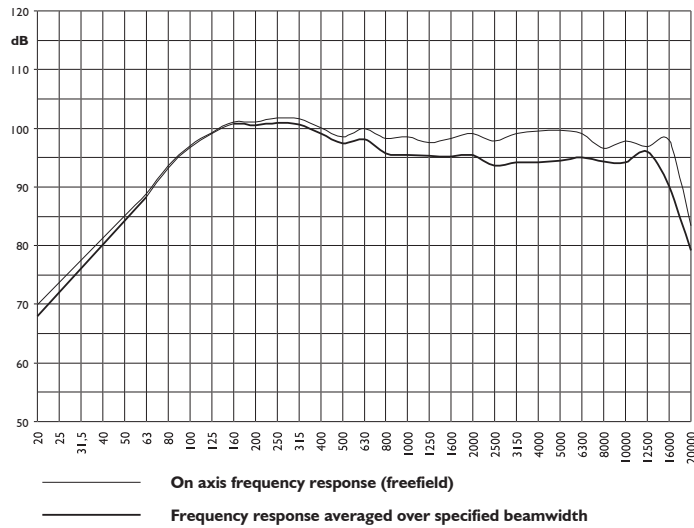

## BEAMWIDTH (-6dB)

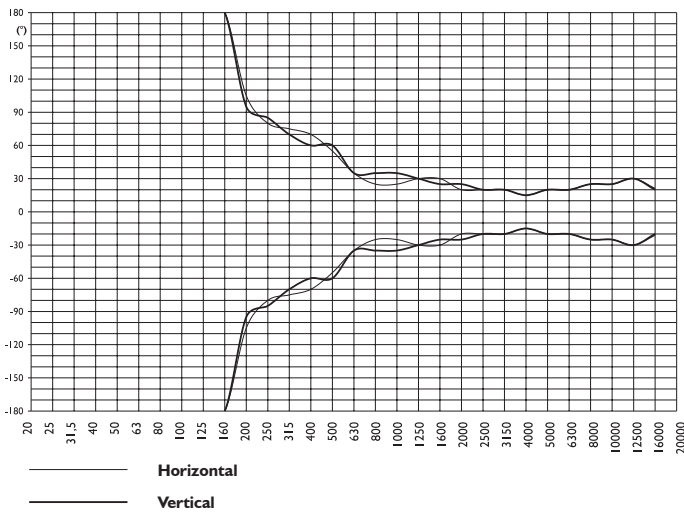

## DIRECTIVITY FACTOR Q

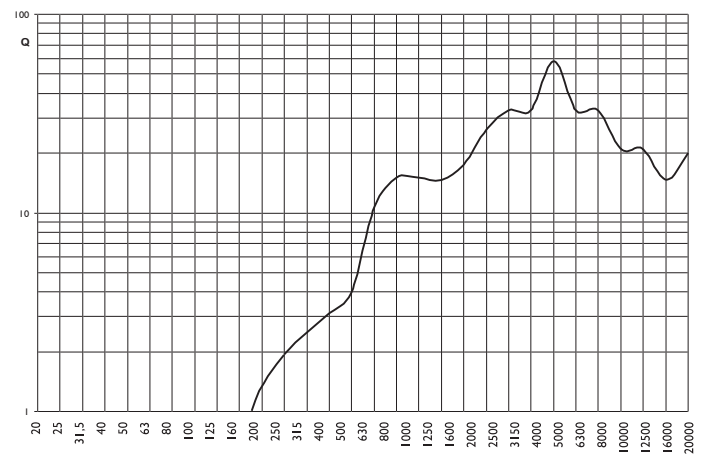

## IMPEDANCE

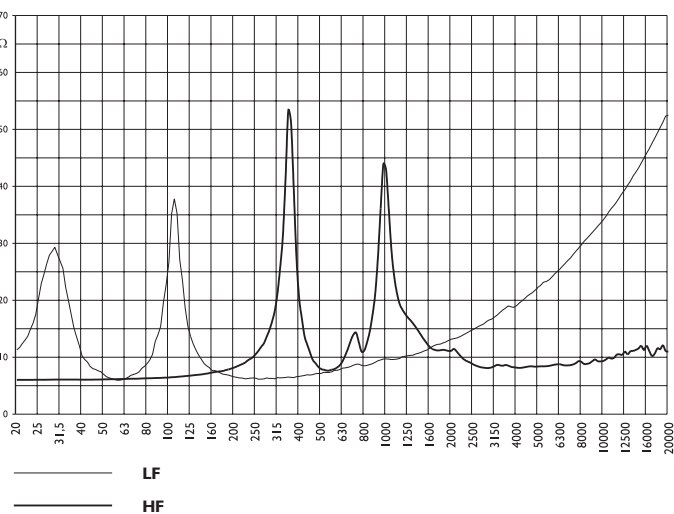



# LLC115FM

## ANALOG CONTROLLER

### DESCRIPTION

The LLC115FM controller is an analog signal processing unit that has been specifically designed to optimize the performance of the I15FM floor monitor. The unit accepts a single input and provides two filtered outputs (low and high frequency) plus an additional output for subwoofer drive.

The LLC115FM contains frequency and phase alignment circuitry for bandwidth limiting, crossover filtering, time alignment and system equalization that is optimized for the I15FM. Sense Return circuitry monitors the power amplifier's output signal to protect loudspeaker components from damage. This processing has no effect on the signal and activates only when unsafe conditions are present due to overheating or excessive voice-coil excursion.

The LLC115FM provides three operating modes:

- **SINGLE** mode activates a 55 Hz high-pass filter combined with low frequency shelving equalization that is suitable for multiple source monitoring and standard stage reinforcement requirements.
- **COUPLED** mode activates an 80 Hz high-pass filter with reduced low frequency shelving equalization. This setting should be used when two monitors are positioned close together to counteract the enhanced low frequency mutual coupling obtained or when it is otherwise desirable to have reduced low frequency output (resonant stage or for vocal-only applications).
- **X-OVER** mode activates a 100 Hz high-pass filter. This setting should be used for speech applications or when the I15FM is used in conjunction with subwoofers.

In terms of connection, the input signal is applied to the line input XLR connector on the front panel of the LLC115FM. Rear panel XLR line outputs (LF, HF) are connected to the power amplifier inputs (Ch A, B, respectively) with the amplifier outputs then connected to the controller "Sense Return" input Speakon connector (Ch A = 1+/1- = LF, Ch B = 2+/2- = HF). Since the amplifier is connected in a loop, LLC sense return protection circuitry can monitor the signal applied to the loudspeakers and provide thermal protection of speaker components plus voltage- and frequency-dependent cone excursion limiting provided that the power amplifier has a gain of 32 dB. The front panel of the LLC115FM is then used as a patch panel with loudspeakers connected via either of the two 4-pin Speakon connectors provided.

### SPECIFICATIONS

#### Technical

Input	Electronically balanced 10 kΩ input (pin 2 hot)
Output	Electronically balanced 50 Ω output (pin 2 hot)
Input Headroom	+20 dBV
Nominal Gain at 200 Hz	0 dB (unity gain)
Signal to Noise	Low-mid section > 80 dB High section > 92 dB
Dynamic Range	> 100 dB
THD	<0.01% (20 to 20k Hz @ 0 dBV)
Bandpass/Equalization Filters	3 modes: 55 Hz (HP+EQ), 80 Hz (HP), 100 Hz (HP) Low-pass: 20 kHz Subwoofer: 40 - 100 Hz (LR 24 dB/octave slopes)
Crossover Filter	1 kHz (LR 24 dB/octave slope)
Analog Delay	Active all-pass
Speaker Protection	Low-mid: RMS limiter & peak limiter High: RMS limiter

#### Front & Rear Panel

Indicators	Signal: green LED for each section Control: yellow LED for each section
Front Panel Controls	AC power, MODE select
Front Panel Connectors	Signal input/output: male/female 3-pin XLR Loudspeaker: 2 parallel 4-pin Neutrik speakon
Rear Panel Connectors	Sense return: 4-pin Neutrik speakon SUB, HF, LF XLR line outputs
Power Requirement	100 V - 240 V 50/60 Hz
Power Consumption	15 W
<b>Physical</b>	
Finish	Black anodized front panel, white serigraphy
Net Dimensions	483 x 44 x 305 mm 19 x 1.75 x 12.0 in
Net Weight	3.7 kg    8.2 lbs
Shipping : Weight	4.8 kg    10.6 lbs
Dimensions	505 x 80 x 415 mm 19.9 x 3.1 x 16.3 in

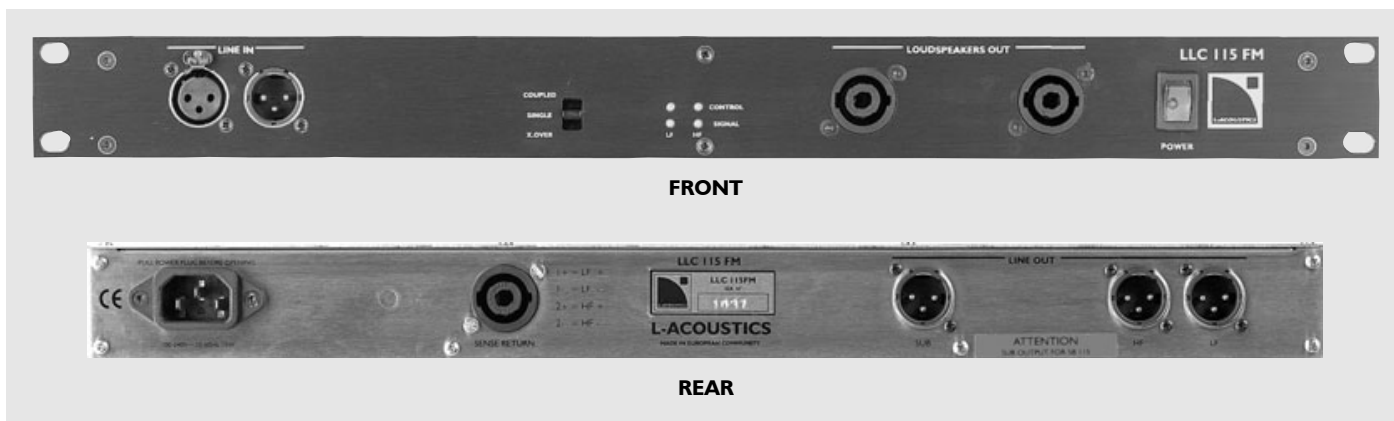

Specifications subject to change without notice

Specs I15FM 0103

### L-ACOUSTICS US

2201 East Celsius Avenue, Suite C  
Oxnard, CA 93030 • USA  
Ph: +1 (805) 604 0577  
Fax: +1 (805) 604 0858

info@l-acoustics-us.com • www.l-acoustics-us.com

### L-ACOUSTICS

Parc de la Fontaine de Jouvence  
91462 Marcoussis Cedex • France  
Ph: +33 (0) 1 69 63 69 63  
Fax: +33 (0) 1 69 63 69 64

info@l-acoustics.com • www.l-acoustics.com

### L-ACOUSTICS UK

16 Dews Road • Salisbury  
Wiltshire, SP2 7SN • UK  
Ph: +44 (0) 1722 411 234  
Fax: +44 (0) 1722 411 236

info.uk@l-acoustics.com • www.l-acoustics.com