



# 115XT HiQ

COAXIAL  
TECHNOLOGY

## APPLICATIONS

The L-ACOUSTICS® 115XT HiQ loudspeaker enclosure, combined with the power of digital signal processing, provides a versatile system that is designed for high performance stage monitoring or distributed sound reinforcement. Combining the advantages of coaxial technology with the pattern control of conical waveguide loading, the 115XT HiQ features advanced components in a flexible, multipurpose format that is suitable for either touring or fixed installation.

The 115XT HiQ is an active 2-way loudspeaker enclosure containing a 1.4" exit neodymium compression driver loaded by a conical waveguide and assembled in a coaxial configuration along with a 15" loudspeaker. Conical waveguide loading focuses mid/high frequency energy over a 50-degree axi-symmetrical pattern while loading the 15" loudspeaker for improved upper mid bass efficiency, resulting in exceptional power response stability with high immunity to feedback.

Further advantages of the coaxial approach include: single point source radiation, total wavefront coherency at all frequencies and superimposed LF/HF dispersion characteristics that are free of polar lobing effects typical of traditional horn and woofer combinations. The net result is natural, studio monitor level sound quality that is ideal for proximity use.

For floor monitoring, the ultra-compact format and low profile of the 115XT HiQ allows for optimum sightlines even in the most confined locations and with the flexibility of dual angle configurations, the 115XT HiQ can be used for either short- or long-throw monitoring. When used with the SB118 (or other L-ACOUSTICS subwoofers), the 115XT HiQ provides an exceptionally high performance side fill or drum monitoring solution.

The 115XT HiQ is also ideal for distributed sound reinforcement and can be used in medium power front-of-house (FOH) applications for theatres, clubs, multi-purpose venues or corporate events.

Application-engineered OEM presets are available for a number of approved digital processors, providing flexible solutions for a wide variety of 2- and 3-way operating modes. FRONT presets are for standalone operation (without subwoofers), FILL presets provide nominally flat response for speech or classical music reinforcement and MONITOR presets account for half-space loading conditions for floor monitoring or fixed installations where the 115XT HiQ is wall- or ceiling-mounted. A variety of 3-way presets are also provided for use of the 115XT HiQ with L-ACOUSTICS subwoofers.

Pole mount sockets and side-mounted fly track sections are included as standard on the 115XT HiQ and optional rigging accessories include an adjustable U-bracket and a vertical coupling adapter.

## L-ACOUSTICS PROFESSIONAL SOUND SYSTEM



- ▶ **Bi-amplified two-way enclosure (15" LF, 1.4" HF)**
- ▶ **High Q coaxial driver assembly**
- ▶ **Point source radiation (50° conical directivity)**
- ▶ **Compact, versatile format for short- or long-throw floor monitoring**
- ▶ **Suitable for medium-power FOH and fill applications**
- ▶ **Designed for high performance touring and fixed installation**
- ▶ **Compact, rugged construction, advanced rigging**
- ▶ **Application-engineered OEM presets for approved digital processors**

## SPECIFICATIONS

L-ACOUSTICS specifications are based on measurement procedures which produce unbiased results and allow for realistic performance prediction and simulation. Some of these specifications will appear very conservative when compared with other manufacturer's specifications. All measurements are conducted under free field conditions and scaled to a 1 m reference distance unless otherwise indicated.

### Frequency Response

Frequency response	65 - 18k Hz (± 3 dB)	(FRONT preset)
Usable bandwidth	50 - 20k Hz (-10 dB)	

### Sensitivity<sup>1</sup>

LF (2.83 Vrms @ 1m)	100.8 dB SPL	65 - 1k Hz
HF (2.83 Vrms @ 1m)	110.2 dB SPL	1 - 18 kHz

### Power Rating<sup>2</sup>

LF 60 Vrms	450 Wrms	1800 Wpeak
HF 32 Vrms	125 Wrms	500 Wpeak

### Amplification

(Recommended)	900 W
	500 W

### Impedance

(Nominal)	8 ohms
	8 ohms

### Nominal Directivity (-6dB)<sup>3</sup>

Axi-symmetrical	50° (± 10°)
-----------------	-------------

### System Output<sup>4</sup>

System Output <sup>4</sup>	SPL		
One enclosure	125 dB (cont)	131 dB (peak)	FRONT Preset
	126.5 dB (cont)	132.5 dB (peak)	FILL Preset
	129.5 dB (cont)	135.5 dB (peak)	MONITOR Preset

FRONT preset provides 3 dB low and high frequency contours under freefield conditions

FILL preset provides nominally flat response under freefield conditions

MONITOR preset provides nominally flat response under halfspace conditions

### Components

LF	1 x 15" weatherproof loudspeaker (bass reflex-loaded, 3" voice coil)
HF	1 x 1.4" neodymium compression driver mounted on conical waveguide

<sup>1</sup> Sensitivity is the average SPL measured over the component's rated bandwidth

<sup>2</sup> Power rating displays the long term RMS power handling capacity using pink noise with a 6 dB crest factor over the component's rated bandwidth

<sup>3</sup> Directivity is averaged over the 1-10 kHz range

<sup>4</sup> System Output gives the unweighted SPL output of the system referenced to 1 m, including preset equalization and band leveling adjustment.

### Enclosure

- Height 365 mm 14.4 in
- Width 580 mm 22.8 in
- Depth 446 mm 17.6 in
- Projection angles : 30° or 60° with respect to vertical axis
- Weight 28.5 kg 62.8 lbs
- Shipping Weight 30.0 kg 66.1 lbs
- Shipping Dims 650 x 550 x 500 mm 25.6 x 21.7 x 19.7 in
- Connectors : 2x 4-pin Neutrik speakon
- Material : Baltic Birch plywood
- Finish : Maroon-gray™
- Grill : Black epoxy perforated steel with acoustically transparent, technically-advanced grille cloth
- Rigging : Integrated flying hardware, handles and pole mount socket

### Additional Equipment

- OEM factory presets available for approved digital processors
- L-ACOUSTICS SB115, SB118, SB218, dV-SUB subwoofers
- L-ACOUSTICS LA 24a power amplifier

## ARCHITECT SPECIFICATIONS

The enclosure shall be a bi-amplified, two-way, coaxial full range loudspeaker containing one direct radiating, bass reflex-loaded, 15 inch low frequency transducer and one 1.4 inch exit, titanium alloy diaphragm, neodymium compression driver. As a full range system, the frequency response shall be 65 Hz to 18 kHz with less than  $\pm 3$  dB variation and the usable bandwidth shall be 50 Hz to 20 kHz (-10 dB).

Pattern control loading for the compression driver shall be provided by a concentrically-mounted conical waveguide that yields a 50-degree conical dispersion pattern that is axi-symmetrical. The crossover point between low and high frequency components shall be 1 kHz with 24 dB per octave Linkwitz-Riley characteristics. Long term power handling shall be 450 Wrms for the low section and 125 Wrms for the high section at a nominal 8-ohm impedance. Connection to the loudspeaker shall be made via two parallel 4-pin Neutrik Speakon connectors.

The enclosure shall have a profile that is suitable for stage monitoring applications, offering two listening angles of 30- or 60-degrees with respect to a vertical axis perpendicular to the floor. Dimensions shall be 58 cm (22.8 in) wide, 44.6 cm (17.6 in) deep and the height above floor level shall be 36.5 cm (14.4 in) when used as a floor monitor in the 30-degree position. Cabinet construction shall consist of 18 mm (0.70 in) and 30 mm (1.18 in) Baltic birch plywood with joints that are sealed, screwed and rabbeted. The finish shall be maroon-gray high resilient paint. The front of the enclosure shall be protected by a black powder-coated, 1.5 mm (0.06 in) thick steel grill that is covered with acoustically-transparent, highly-resistant, technically-advanced grille cloth.

The enclosure shall be used with an approved digital processor with OEM factory presets for active 2-way or 3-way operation in conjunction with additional subwoofer enclosures.

The loudspeaker system shall be the L-ACOUSTICS I15XT HiQ.

The subwoofer system shall be the L-ACOUSTICS SB115, SB118, SB218 or dV-SUB.

## ACCESSORIES

**ETRI15XT:** Adjustable U-Bracket for ceiling, wall or scaffold mounting of the I15XT HiQ in either horizontal or vertical orientations.

**CPLI15XT:** Coupling adapter bars used in conjunction with ETRI15XT to array two I15XT HiQ vertically with independent tilt adjustment for both enclosures.

**XTLIFTBAR:** Allows for single point rigging of the I15XT HiQ with 5 pick points available for tilt adjustment.

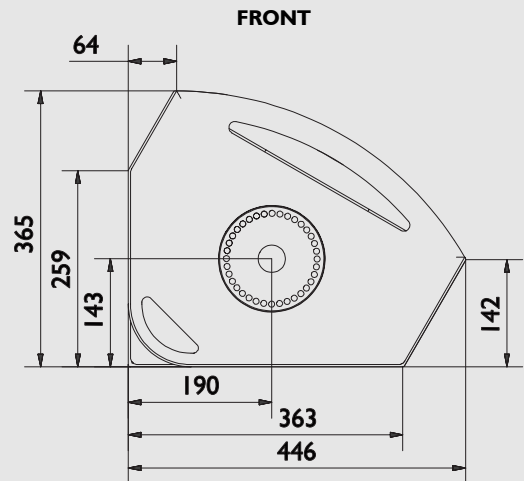
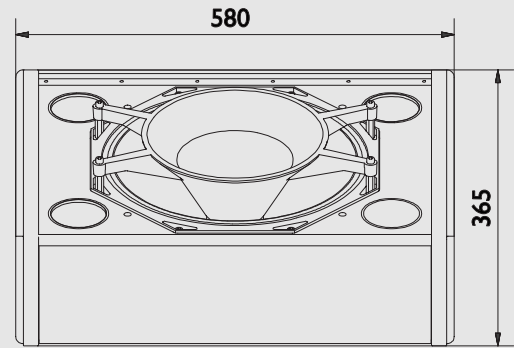

SIDE

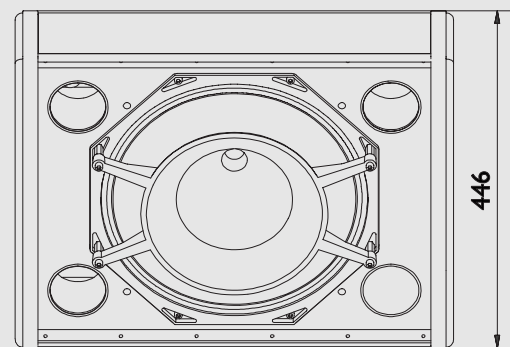

TOP

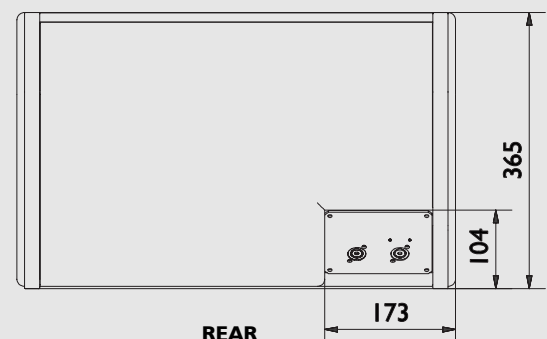

REAR

SCALE 1:10

(Dimensions in mm)



# 115XT HiQ

PERFORMANCE  
DATA

## FREQUENCY RESPONSE

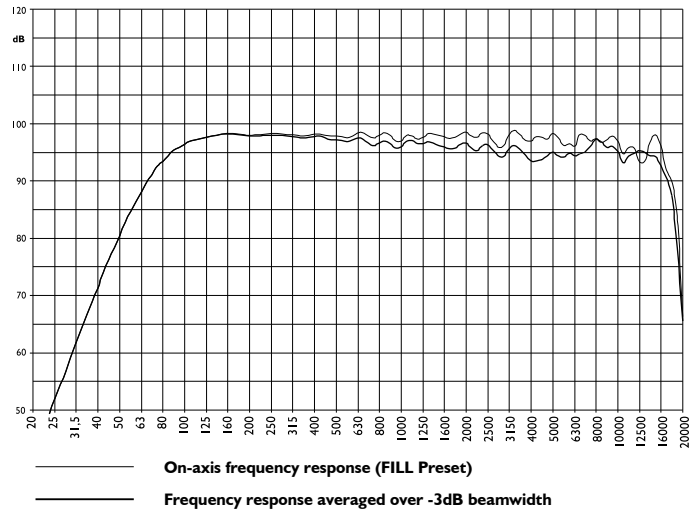

## BEAMWIDTH (-6dB)

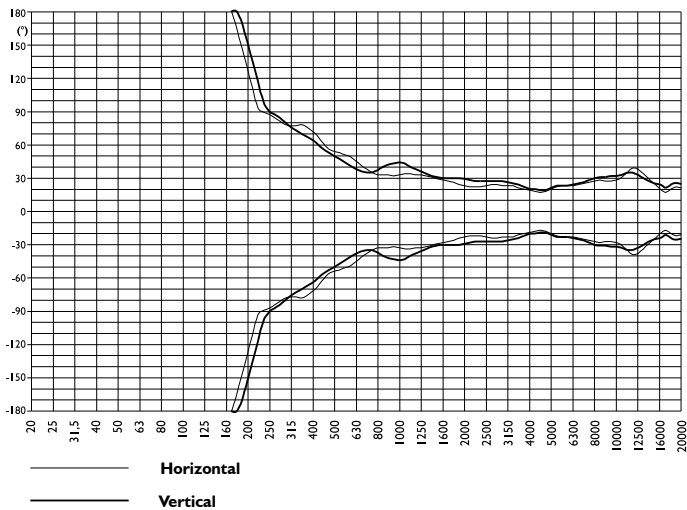

## DIRECTIVITY FACTOR Q

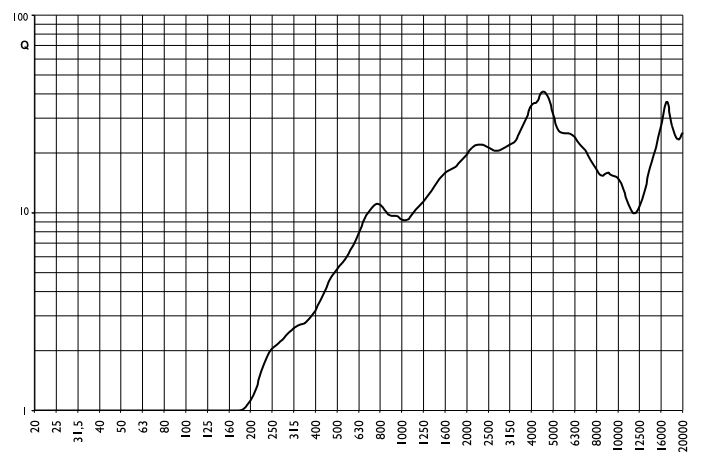

## IMPEDANCE

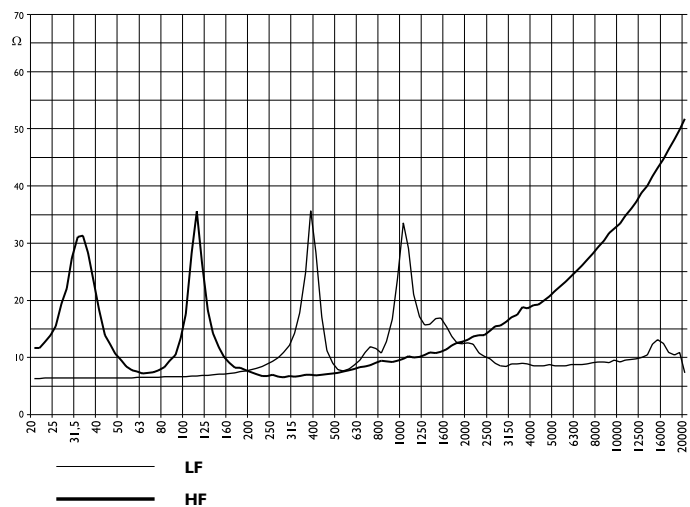

## FURTHER INFORMATION

### OEM Factory Presets

- For 2-way operation, three types of presets are provided: FRONT presets are for standalone FOH operation (without subwoofers) where low and high frequency shelving equalization provides a frequency response contour suitable for music applications. FILL presets provide nominally flat response for use in speech reinforcement and classical music applications or when the I15XT HiQ is used as a close proximity fill enclosure. Both FRONT and FILL presets are derived under freefield measurement conditions. MONITOR presets include additional low frequency equalization to account for half-space loading conditions and are intended for floor monitoring applications or fixed installations where the I15XT HiQ is wall- or ceiling-mounted.
- A variety of 3-way presets are provided for use of the I15XT HiQ with SB115, SB118, SB218 or dV-SUB subwoofers. Standard 3W presets utilize a complimentary 100 Hz crossover point for the I15XT HiQ and its companion subwoofer and are recommended for closely coupled applications. Alternatively, when the I15XT HiQ is flown and subwoofers are ground stacked, 3WX presets can be employed where an 80 Hz low pass filter is applied to the subwoofers and I15XT HiQ low frequency response extends to 45 Hz.

